

KART RAIN LIGHT INSTRUCTIONS

INTRODUCTION

Designed to meet the MSUK Karting regulations. This Rain Light is F2.9 compliant.

OPERATION

Switch ON/OFF:

Press and hold pushbutton for 1 second.

Check Battery Charge Level:

Quick press of pushbutton whilst ON or OFF.

4x LEDs = Battery full, 75%-100%. (approx 3 hours use)

3x LEDs = 50%-75%.

2x LEDs = 25%-50%, re-charge recommended.

1x LED = Battery very low, re-charge immediately.

Battery Charging:

Battery charging is via USB cable supplied which is inserted into rear of light.

WARNING: Use rubber seal supplied to keep charging socket clear of dirt and water.

INSTALLATION

Mount securely using the 2 x M4 screws and nuts provided.

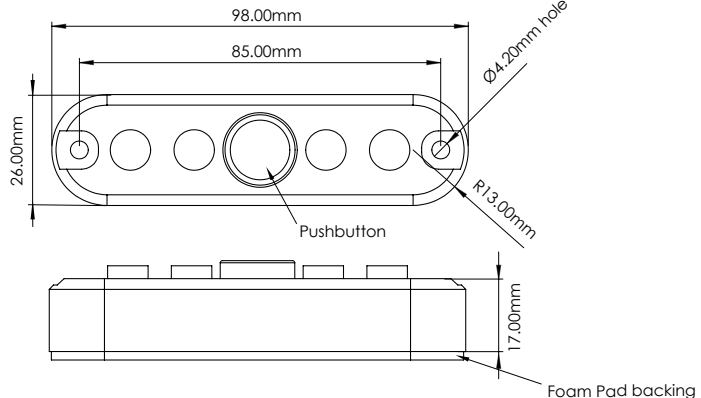

SPECIFICATION

Kart Rain Light Part Number:	CK-LK-01
Size:	98.0 x 66.0 x 17.0mm
Weight:	85g
Battery Life:	3 hours (when switched on)
Brightness:	60cd (minimum)
Construction:	One-piece solid resin moulding
Charging Cable Part Number:	CK-LK-CABLE