



NOTE

All numerical values are in metric units [with U.S. customary units in brackets]. Dimensions are in millimeters. Unless otherwise specified, dimensions have a tolerance of ± 0.13 mm and angles have a tolerance of $\pm 2^\circ$. Figures and illustrations are for identification only and are not drawn to scale.

1. INTRODUCTION

This specification covers the requirements for application of the AMPSEAL automotive plug connector and header assembly. The plug will accept multiple socket contacts. All plugs and headers are color coded as a positive mating feature.

When corresponding with TE Connectivity Personnel, use the terminology provided in this specification to facilitate inquiries for information. Basic terms and features of this product are provided in Figure 1.

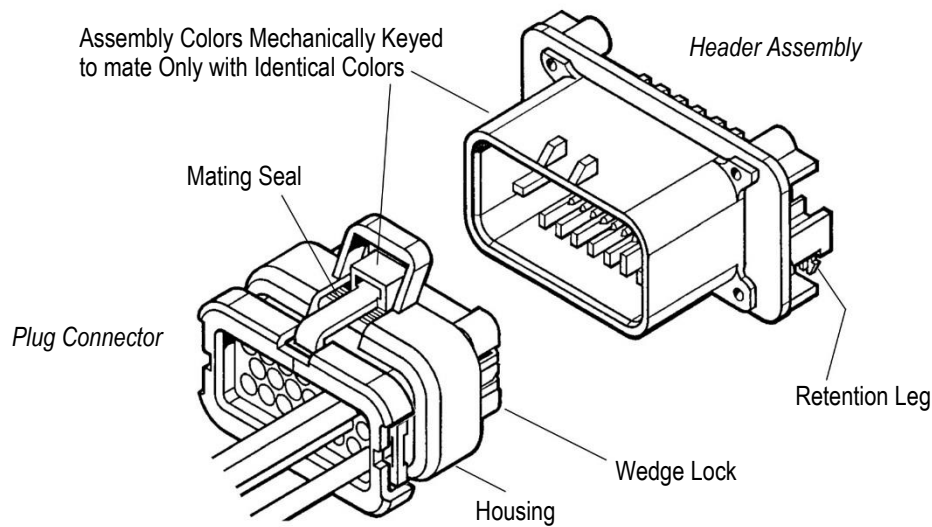

Figure 1

2. REFERENCE MATERIAL

2.1. Revision Summary

- Updated document to corporate requirements
- Changed hole dimension in Figure 10
- Changed screw type in Paragraph 3.6.B

2.2. Customer Assistance

Reference Product Base Part Number 770520 and Product Code J561 are representative numbers that identify the AMPSEAL automotive plug connector and header assembly. Use of these numbers will identify the product line and help you to obtain product and tooling information. Such information can be obtained through a local TE Representative, by visiting our website at www.te.com, or by calling PRODUCT INFORMATION or the TOOLING ASSISTANCE CENTER at the numbers at the bottom of this page.

2.3. Drawings

Customer Drawings for product part numbers are available from the service network. If there is a conflict between the information contained in the Customer Drawings and this specification or with any other technical documentation supplied, the information contained in the Customer Drawings takes priority.

2.4. Specifications

This product meets or exceeds the requirements outlined in specification ISO/CD 8092/2.

2.5. Instructional Material

The following instruction sheets (408-series) are supporting documents available to assist with product assembly and tool setup and operation.

<u>Document</u>	<u>Document Title</u>
408-3229	AMPSEAL Automotive Plug Assemblies 776268-[], 776273-[], 770680-[], and 776164-[]
408-9592	Hand Crimping Tool 58440-1
408-9999	PRO-CRIMPER* III Hand Tool Assembly 58529-1 with Die Assembly 58529-2
408-8040	Heavy Duty Miniature Quick-Change Applicators with Mechanical Feed System

3. REQUIREMENTS

3.1. Safety

Do not stack product shipping containers so high that the containers buckle or deform.

3.2. Storage

A. Ultraviolet Light

Prolonged exposure to ultraviolet light may deteriorate the chemical composition used in the product material.

B. Shelf Life

The product should remain in the shipping containers until ready for use to prevent deformation to components. The product should be used on a first in, first out basis to avoid storage contamination that could adversely affect performance.

C. Chemical Exposure

Do not store product near any chemical listed below as they may cause stress corrosion cracking in the material.

Alkalies	Ammonia	Citrates	Phosphates	Citrates	Sulfur Compounds
Amines	Carbonates	Nitrites	Sulfur Nitrites		Tartrates

3.3. Wire

A. Wire Selection

The contact will accept wire ranging in size from 20 to 16 AWG and 1.5 mm². Wire insulation diameter shall be a minimum dimension of 1.7 mm and a maximum dimension of 2.7 mm.

B. Wire Preparation

Wire strip length shall be 5.1 ±0.4 mm. Reasonable care shall be taken during the stripping operation to ensure the conductor is not nicked, scraped, or cut.

3.4. Crimped Contact

A. Crimping

The contacts shall be crimped in accordance with the material packaged with the tooling; refer to the charts in Figure 2.



CAUTION

*Contacts are available in loose piece form for hand tool crimping. **Do not** cut strip form (reeled) contacts into loose piece form. This will produce burrs on the cutoff tab which will damage the wire seal in the plug.*

B. Inspection

Inspect crimped contacts for conditions shown in Figure 2.

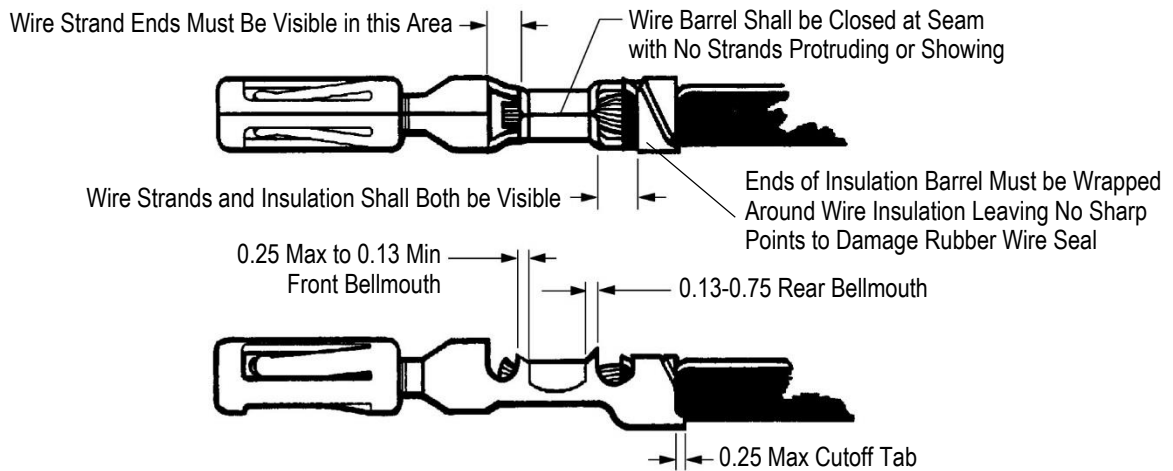

WIRE		WIRE BARREL			INSULATION BARREL	
SIZE	INSULATION DIA RANGE	STRIP LENGTH ± 0.4	CRIMP HEIGHT	CRIMP WIDTH (NOMIAL)	CRIMP HEIGHT (MAX)	CRIMP WIDTH ± 0.1
mm ²	AWG					
0.5	20	5.1	1.17 \pm 0.05	2.03	3.2	3.1
0.8	18		1.27 \pm 0.05			
1	---		1.28 \pm 0.05			
1.4	16		1.40 \pm 0.05			
1.5	---	2.2-2.4	1.40 \pm 0.05			

Figure 2



NOTE

Wire stripping tool jaws may leave corrugated indentations on the surface of the wire insulation. This is especially severe with cross-linked polyethylene (high temperature) insulation. If these indentations occur at the location of the wire seal, leakage may result. Insulation surface within 26 mm from the tip of the contact must be smooth and free of residual indentations.



CAUTION

It is important in any application that the far end of the cable be sealed or otherwise isolated from the environment and that the insulation is not cut or damaged.



CAUTION

Care shall be taken to ensure that the wire insulation is not cut or broken during the crimping operation and to ensure that the insulation is not crimped into the wire barrel.

C. Further Processing

Care must be taken when transporting, storing, or further processing the crimped contacts and wires that any damage or soiling of the contact body or crimped area is avoided. When processing the end of the wire or anywhere along the wire, damage or impairment of the crimped contact must be avoided.

For a twisting operation after crimping or mounting a contact to its housing, the twist must end at least 35 mm away from the contact. Additional care must be taken during or after the twisting operation to avoid any pulling force to the contact or crimped area that may affect the function of the connector.

TE has not tested, nor otherwise verified, contact performance after processing of the connected wire by ultrasonic welding. TE does not make any representation or warranty, expressed or implied, and disclaims any and all liability, on any legal basis whatsoever, for contact performance after ultrasonic welding of the connected wire. Customer takes sole responsibility for the evaluation, application, and use of contacts in such circumstances.

3.5. Plug Connector

A. Assembly

Before starting assembly, the wedge lock must be in the **open**, or as-shipped, position. Refer to Figure 3.

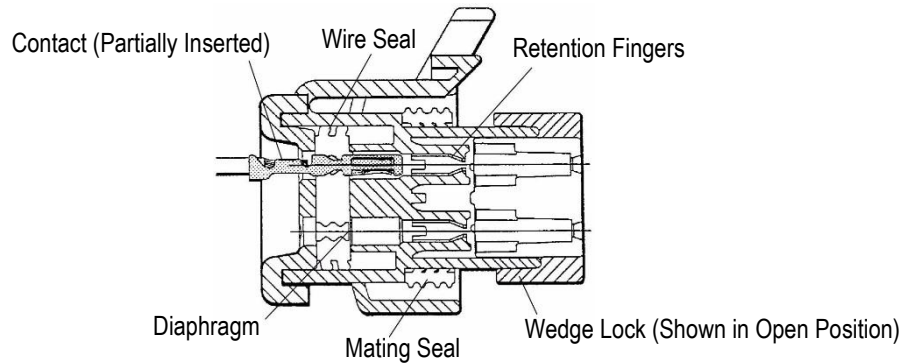

Figure 3

The plug must be assembled as follows:

1. To insert a contact, push it straight into the appropriate circuit cavity as far as it will go (see Figure 4).
2. Pull back on the contact wire with a force of 4.45 or 8.9 N [1 or 2 lb-force] to be sure the retention fingers are holding the contact (see Figure 4).

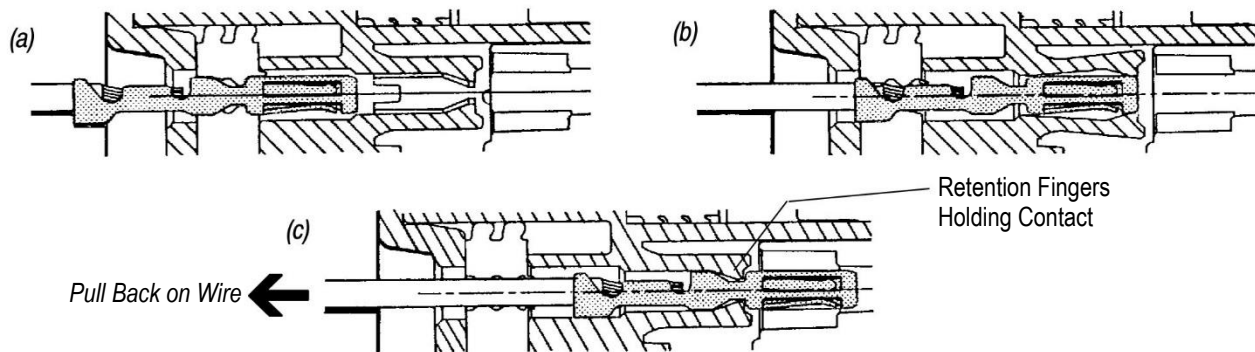

Figure 4

3. After all required contacts have been inserted, the wedge lock must be closed to its locked position. Release the locking latches by squeezing them inward (see Figure 5).

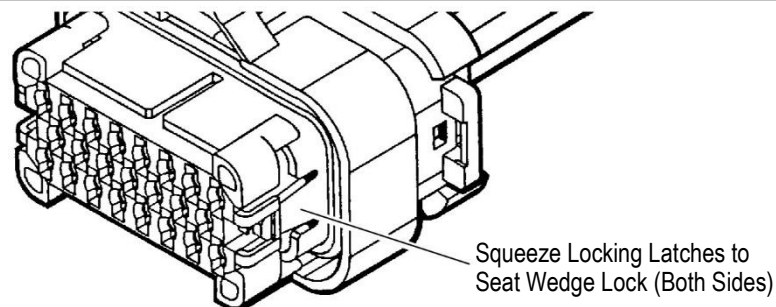

Figure 5

4. Slide the wedge lock into the housing until it is flush with the housing (see Figure 6).

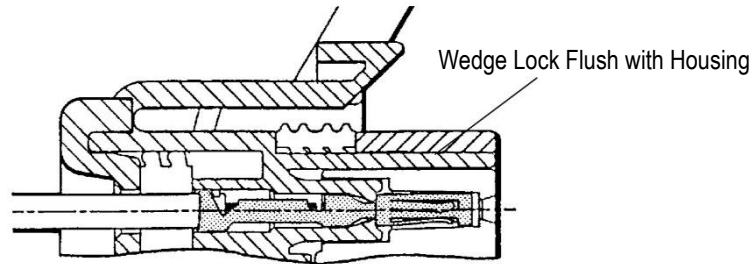

Figure 6

B. Disassembly

The plug must be disassembled (contacts removed) as follows (refer to Figure 7):

1. Insert a 4.8-mm wide screwdriver blade between the mating seal and one of the red wedge lock tabs.
2. Pry open the wedge lock to the open (as shipped) position.
3. While rotating the wire back and forth over a half turn (one-quarter turn in each direction), gently pull the wire until the contact is removed.



NOTE

The wedge lock should never be removed from the housing for insertion or removal of the contacts.

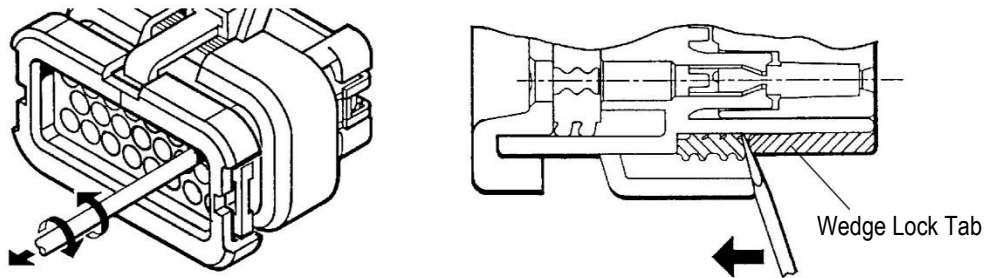

Figure 7

C. Seal Plug

All circuits are sealed by a diaphragm in the rubber wire seal. During plug assembly, the diaphragm is pierced as the contact passes through it. Unused circuit cavities, unless accidentally perforated, will remain sealed. Seal plug 770678-1 is designed to keep out contaminants if diaphragm is pierced. Insert seal plug, **large end first**, into the circuit cavity as far as it will go. An insertion tool is not required for this procedure as shown in Figure 8.

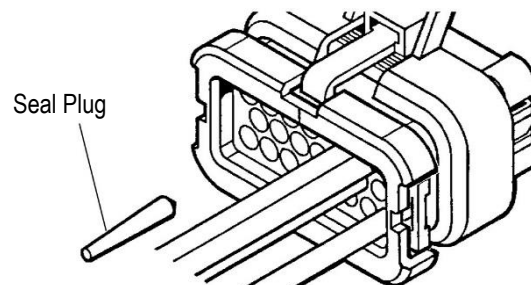

Figure 8

D. Circuit Testing

The wedge lock has slotted openings in the forward, or mating end. These slots accommodate circuit test tabs that are approximately 3.3 x 0.6 mm, which prevent damage to the header. For circuit testing in the field, use a flat probe such as a pocket knife blade. Do not use a sharp point such as an ice pick.

E. Application

Refer to Figure 9 for the opening size that will clear a completed plug assembly.

CONTACT ASSEMBLY	OPENING SIZE
35 Position	Ø66 mm
23 Position	Ø50 mm
14 Position	Ø44 mm
8 Position	Ø40 mm

Figure 9

F. Service Voltage Reading



CAUTION

Do **not** pierce wire insulation to take voltage readings.

It has been common practice in electrical troubleshooting to probe wires by piercing the insulation with a sharp point. This practice should be discouraged when dealing with the AMPSEAL plug or any other sealed connector system. The resulting pinholes in the insulation will allow moisture to invade the system by traveling along the wire strands. This nullifies the effectiveness of the connector seals and could result in system failure.

3.6. Header Assembly

A. Printed Circuit (PC) Board

The suggested pc board layout requirements shall be as shown in Figure 10. The pc board thickness shall be 1.57 mm.

The header assembly is designed to be compatible with any standard wave soldering process, which uses tin solder. However, there must be no interruptions of the conveyor carrying the pc boards through the solder bath.



CAUTION

Care **MUST** be taken not to leave the AMPSEAL headers exposed directly to the solder flow during an interruption. Any headers exposed to the solder flow longer than the normal soldering cycle must be rejected and replaced.

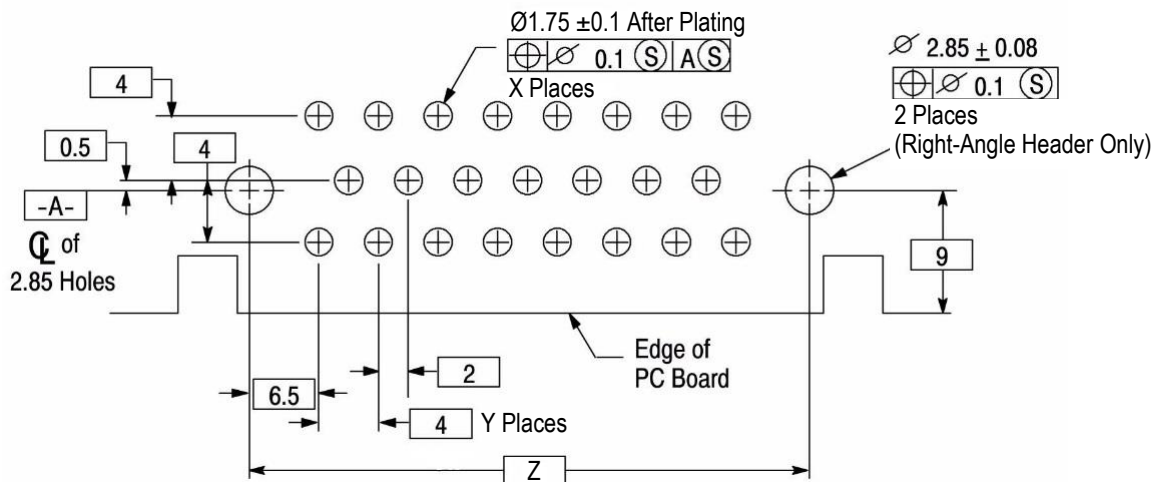

Figure 10 (cont'd)

CONNECTOR SIZE	X	Y	Z
8-Position	8	2	20.60
14-Position	14	4	28.95
23-Position	23	7	41.0
35-Position	35	11	57.0

Figure 10 (end)

B. Panel Mounting

Panel mounting cutout requirements shall be as shown in Figure 11. The panel thickness shall be 2-5 mm for proper assembly clearance. Panel sealing surface shall be in accordance with ISO 1302.

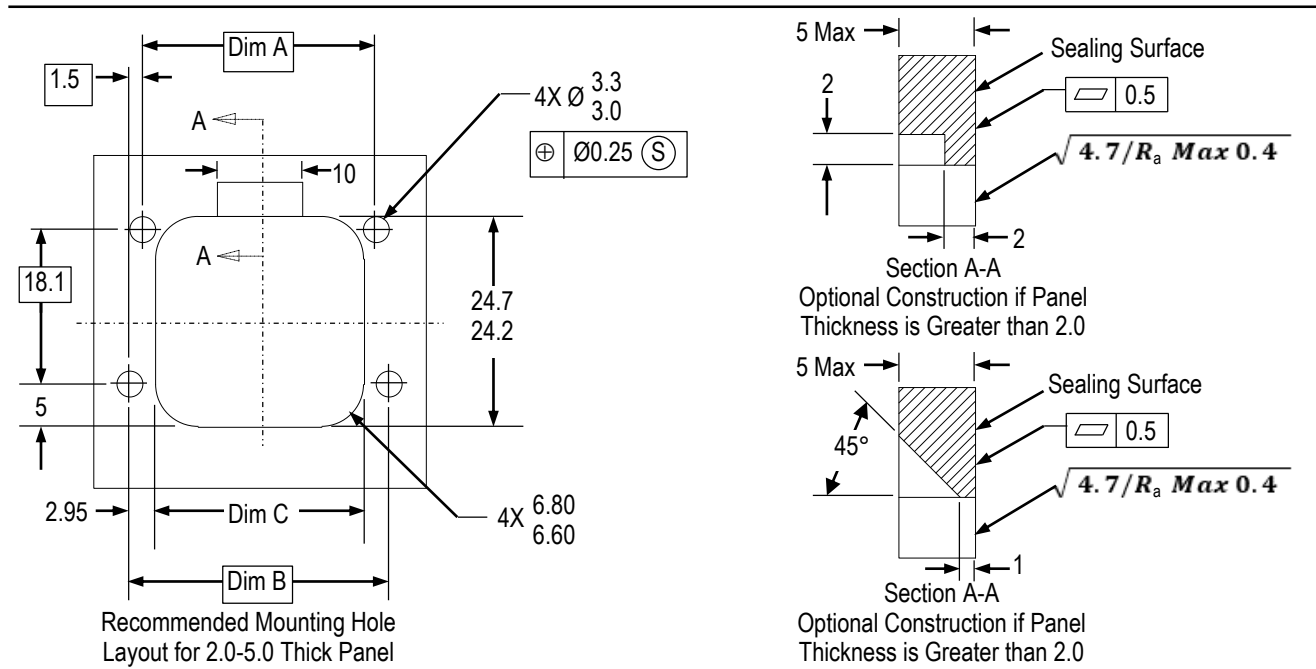

PANEL CUTOUT DIMENSIONS

CONNECTOR SIZE	A	B	C
8-Position	27.4	30.4	24.5-24.0
14-Position	35.4	38.4	32.5-32.0
23-Position	47.4	50.4	44.5-44.0
35-Position	63.4	66.4	60.6-60.0

Figure 11

The header assembly is designed to be fastened to the enclosure by four #3 self-tapping thread-forming screws, such as the DELTA-PT, or metric equivalent. The screw length will depend on the panel thickness. Torque the screws to 0.6 to 0.8 N•m. See Figure 12.

Header assemblies will be provided both with and without a Dispensed-In-Place gasket bonded to the flange. For sealing a bare flange to an enclosure, a loose piece gasket will be required. The customer will be responsible for the design and performance of the gasket.

4. QUALIFICATIONS

AMPSEAL automotive plug connectors are Listed in Underwriters Laboratories Inc. (UL) File E28476 and Certified in CSA International File LR7189.

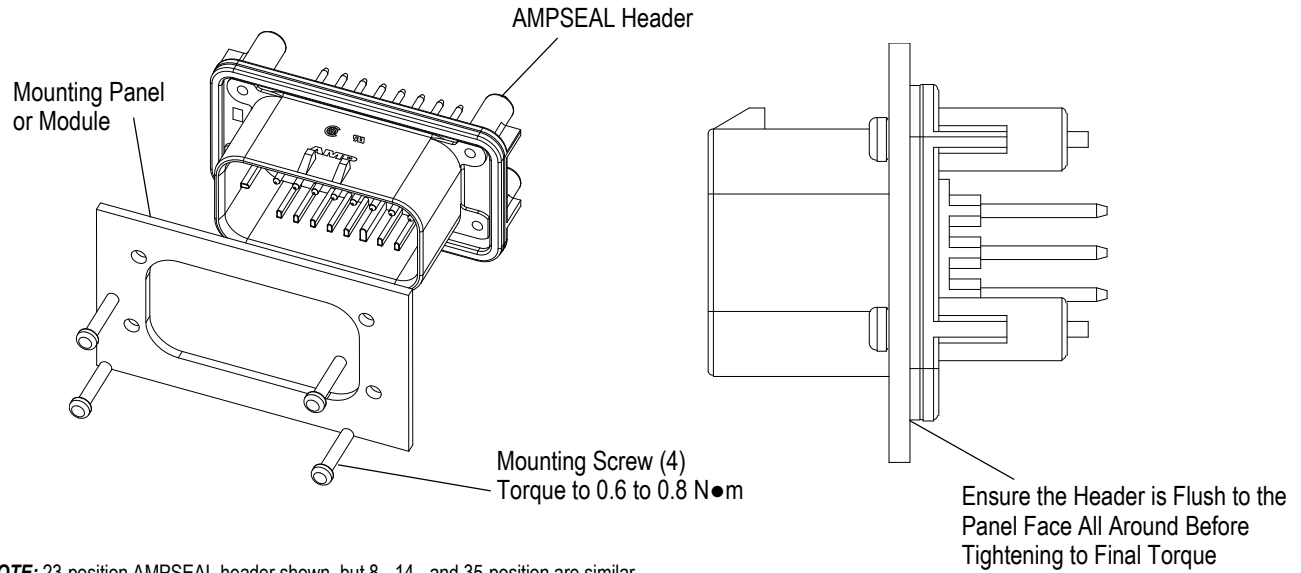

NOTE: 23-position AMPSEAL header shown, but 8-, 14-, and 35-position are similar.

Figure 11

5. TOOLING

Tooling and instruction material for this product are listed in Figure 13. Loose-piece contacts are designed to be crimped with a TE hand tool. Strip-form contacts are designed to be crimped with a miniature applicator used in a semi-automatic or automatic machine. Refer to Instruction Sheet 408-3229 for contact insertion and extraction.

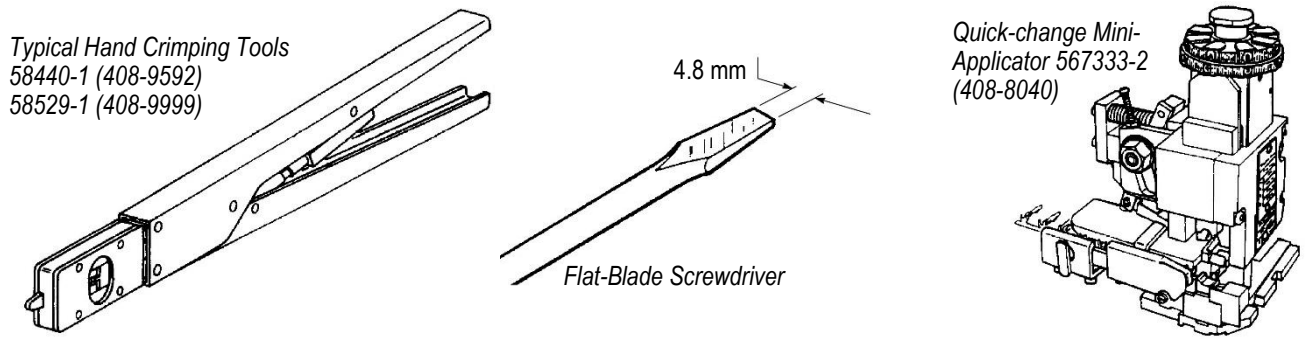

Figure 12

6. VISUAL AID

The illustration below shows a typical application of this product. This illustration should be used by production personnel to ensure a correctly applied product. Applications which do not appear correct should be inspected using the information in the preceding pages of this specification and in the instructional material shipped with the product or tooling.

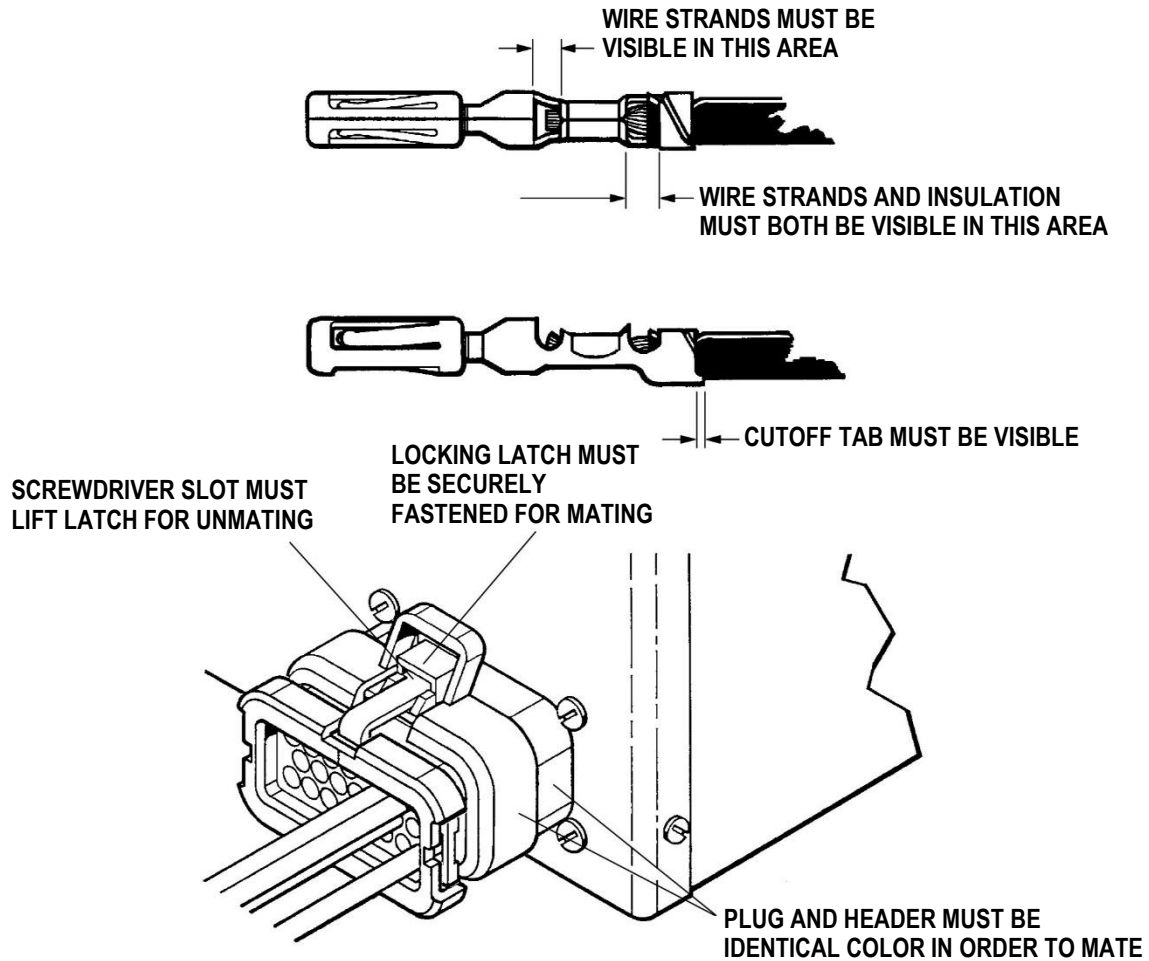

FIGURE 14. VISUAL AID